



Look at the detail

Schlüter®-KERDI-LINE-G3

Low height linear drain compliant with BS EN 1253

78mm

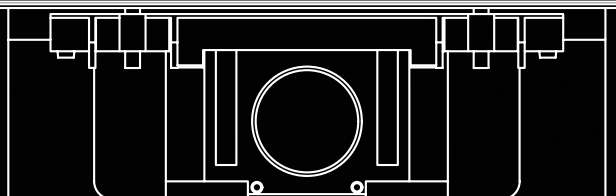

Specifically designed to simplify drainage from tiled showers and wet rooms – whether a new build or refurbishment project. Use in conjunction with the Schlüter®-KERDI system components and other Schlüter products to provide a fully waterproofed integrated system solution, as per ETAG 022 (watertight covering kits).

- ✓ Overall height = 78mm
- ✓ Horizontal outlet – 40mm ID/43mm OD solvent weld, easily converted to 50mm
- ✓ Pre-applied Schlüter®-KERDI waterproofing collar
- ✓ ‘Shutter’ gate clamp secures O-ring, creating a tight seal
- ✓ Air tightness as per Building Regulations
- ✓ Intermediate/central or wall/perimeter installation positions
- ✓ Choice of 8 channel lengths, 500mm to 1200mm in 100mm increments
- ✓ Central, offset or dual outlet options



Schlüter®-KERDI-LINE-G3 (Intermediate installation)



Schlüter®-KERDI-LINE-G3 (Wall abutment installation)

Product Codes

L = Channel Length (mm)	Outlet Centre	outlet offset* left	outlet offset* right	outlet offset* dual
500	KL F 43 G3E 50			
600	KL F 43 G3E 60			
700	KL F 43 G3E 70	KL FOL 43 G3E 70	KL FOR 43 G3E 70	
800	KL F 43 G3E 80	KL FOL 43 G3E 80	KL FOR 43 G3E 80	
900	KL F 43 G3E 90	KL FOL 43 G3E 90	KL FOR 43 G3E 90	
1000	KL F 43 G3E 100	KL FOL 43 G3E 100	KL FOR 43 G3E 100	KL F2O 43 G3E 100
1100	KL F 43 G3E 110	KL FOL 43 G3E 110	KL FOR 43 G3E 110	KL F2O 43 G3E 110
1200	KL F 43 G3E 120	KL FOL 43 G3E 120	KL FOR 43 G3E 120	KL F2O 43 G3E 120

*Centre of offset & dual offset outlet(s) = 200mm from end of drainage channel flange

Please contact the Schlüter Sales Office if you require a channel length and/or outlet position(s) not listed above. We may be able to provide a custom-made solution.

Grate Options^o (assuming a 4 mm bed of tile adhesive)



^o Grate Design C is not available for use with Schlüter®-KERDI-LINE-G3

Key Dimensions

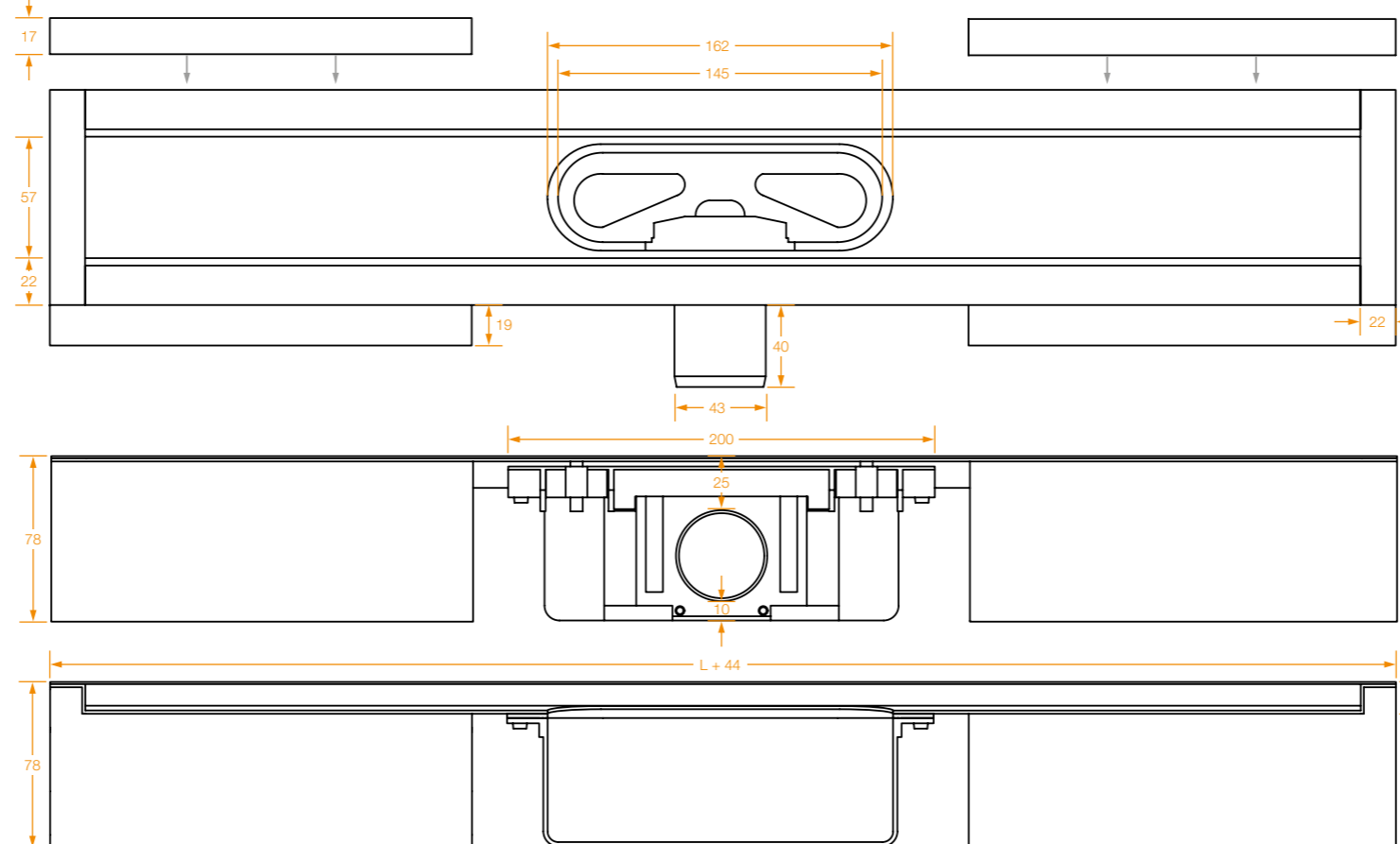

Complies with BS EN 1253 & BS EN 274

- ✓ Water trap/seal = 50mm – easily removed for cleaning
- ✓ Anti-blockage as per 8mm ball bearing test
- ✓ Odour tightness of 180Pa for 15 mins
- ✓ Water flow rate* = 0.45 l/s (27 l/min) single outlet = 0.80 l/s (48 l/min) dual outlet
- ✓ Channel loading strength = class K3 (300kg)
- ✓ Easy access for cleaning

*measured as per BS EN 1253-1, with a 20mm head of water.

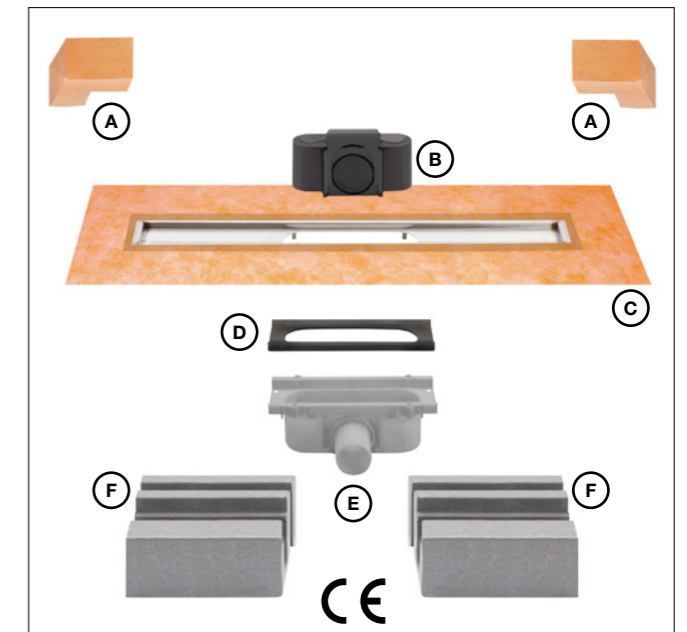

- (A) Schlüter®-KERDI-KERECK prefabricate corner seal for wall abutments
- (B) Water trap/seal
- (C) Drainage channel with pre-adhered Schlüter®-KERDI waterproofing collar
- (D) EPDM gasket
- (E) Drain body/sump
- (F) Polystyrene channel support

Material Specifications

- ✓ Drain channel = stainless steel V4A (316)
- ✓ Water trap/seal = ABS
- ✓ Drain body/sump = ABS
- ✓ Outlet = solvent weld ABS
- ✓ O-ring = silicone
- ✓ Gasket = EPDM
- ✓ Channel support = polystyrene

